

FyreWrap® Elite® 1.5 Duct Insulation – Air Distribution System (ADS Ducts)

Introduction

Unifrax's FyreWrap® Elite® 1.5 Duct Insulation is a single-layer flexible duct wrap enclosure for 1- and 2-hour fire-rated air distribution systems (ADS ducts). Typical duct types include smoke control, hazardous exhaust, laboratory chemical fume, stairwell and vestibule pressurization, ventilation, supply/return ducts, commercial dryer exhaust, as well as refuse and linen chutes. This slim, compact design is an alternate to code prescribed fire-rated shafts and results in significant weight, space and labor savings when compared to traditional shafts.

FyreWrap Elite 1.5 Duct Insulation Air Distribution System (ADS) offers the following features:

- 1- and 2-hour fire-rated enclosure
- Alternate to fire-rated shaft
- Zero clearance to combustibles at all locations on blanket wrap
- Saves weight, space, labor
- Thin, lightweight single-layer system
- High-temperature, biosoluble insulation
- Durable foil-scrim covering
- GREENGUARD listed for Microbial Resistance

Typical Product Parameters

Thickness	1.5"
Nominal Density	6pcf
Standard Product Form	Scrim Encapsulated
Product Availability	1.5" x 24" x 25LF 1.5" x 48" x 25LF

Product Components

Core Material: FyreWrap Elite 1.5 Duct Insulation incorporates Insulfrax® Thermal Insulation as its core material. Insulfrax is a high-temperature insulation made from calcia, magnesia, silica chemistry designed to enhance biosolubility. It provides excellent insulation in a noncombustible blanket form.

Encapsulating Material: The core insulation is completely encapsulated in an aluminum foil, fiberglass-reinforced scrim covering. This scrim provides additional handling strength as well as protection from tearing and moisture absorption.

Complies with: IBC 2006 Sect. 909.10.2; IMC 2006 Sect. 513.10.2, NFPA 92A 2006 Sect. 6.62, NFPA 92B 2005 Sect. 7.5.2, NFPA 101 2006 Sect. 8.6.7, 18.77



FyreWrap® Elite® 1.5 Duct Insulation

Typical Product Properties

Intertek Testing Services	File No. 14870
Design Listings	Duct System: UNI/FRD 120-15
Fire Endurance Rating	ISO 6944 – Type A Duct
Stability	2 Hours
Integrity	2 Hours
Insulation	2 Hours
Firestop Test	F-rating = 2 hrs., T-rating = 2 hrs.
Per ASTM E814, E119	Firestop System: UNI/FRD 120-21, UNI/FRD 120-23, UNI/FRD 120-24, UNI/PHV 120-03, UNI/PHV 120-04
ASTM E84, UL 723, ULC S102.2 – UL File No. R14514	
	Unfaced Blanket Encapsulated
Flame Spread Rating:	0 < 25
Smoke Developed Rating:	0 < 50
ASTM E136	Pass
Non-combustibility	
ASTM C411 Hot	Pass
Surface Performance	
ASTM C518 Durability	Pass; R-Value = 4.8 per inch @ 75°F
ASTM C518 Thermal Resistance	R-Value of Elite 1.5 (1½") = 7.2
ASTM E90	Sound Transmission Class STC = 31 dB
ASTM D6329-03	Resistant to Mold Growth
Microbial Resistance	
California State Fire Marshal Listing	No: 240-1478:100
New York City	Building Bulletin 2009-028



Member
International FireStop Council

Installation

FyreWrap Elite 1.5 Duct Insulation ADS System consists of a single-layer applied directly on to the duct surface. Only encapsulated blanket should be utilized to ensure the outer surface of the insulation is protected. The insulation system may be installed at zero clearance to combustibles at all locations on the wrap – at material overlaps and in the field between overlaps. To minimize waste, FyreWrap Elite 1.5 should be rolled out tautly before measuring and making any material cuts. Install insulation with a 3" minimum overlap on all joints. Seal cut edges with pressure-sensitive aluminum foil tape. The perimeter transverse overlap of adjacent blanket may be installed using any of the following three techniques. See Figure 1 for details.

Telescope Overlap Wrap Technique –

This wrap technique is the most common method of installing FyreWrap Elite 1.5 where each adjacent blanket has one

edge exposed and one edge covered by the next blanket, to form a 3" overlap.

Checkerboard Overlap Wrap Technique –

This installation uses a 3" overlap pattern with both edges of each alternating blanket covered by each adjacent blanket whose edges are exposed. The overlap joints in alternate layers of blanket resemble a checkerboard pattern in the completed installation. This technique is often utilized when a small section of duct wrap must be repaired.

Butt Splice with Collar Wrap Technique –

This wrap technique permits installation with the blanket edges butted together and a 6" wide collar of blanket that is centered over the butt splice, overlapping each adjacent blanket 3". The collar can be field fabricated from FyreWrap Elite 1.5 rolls or purchased separately.

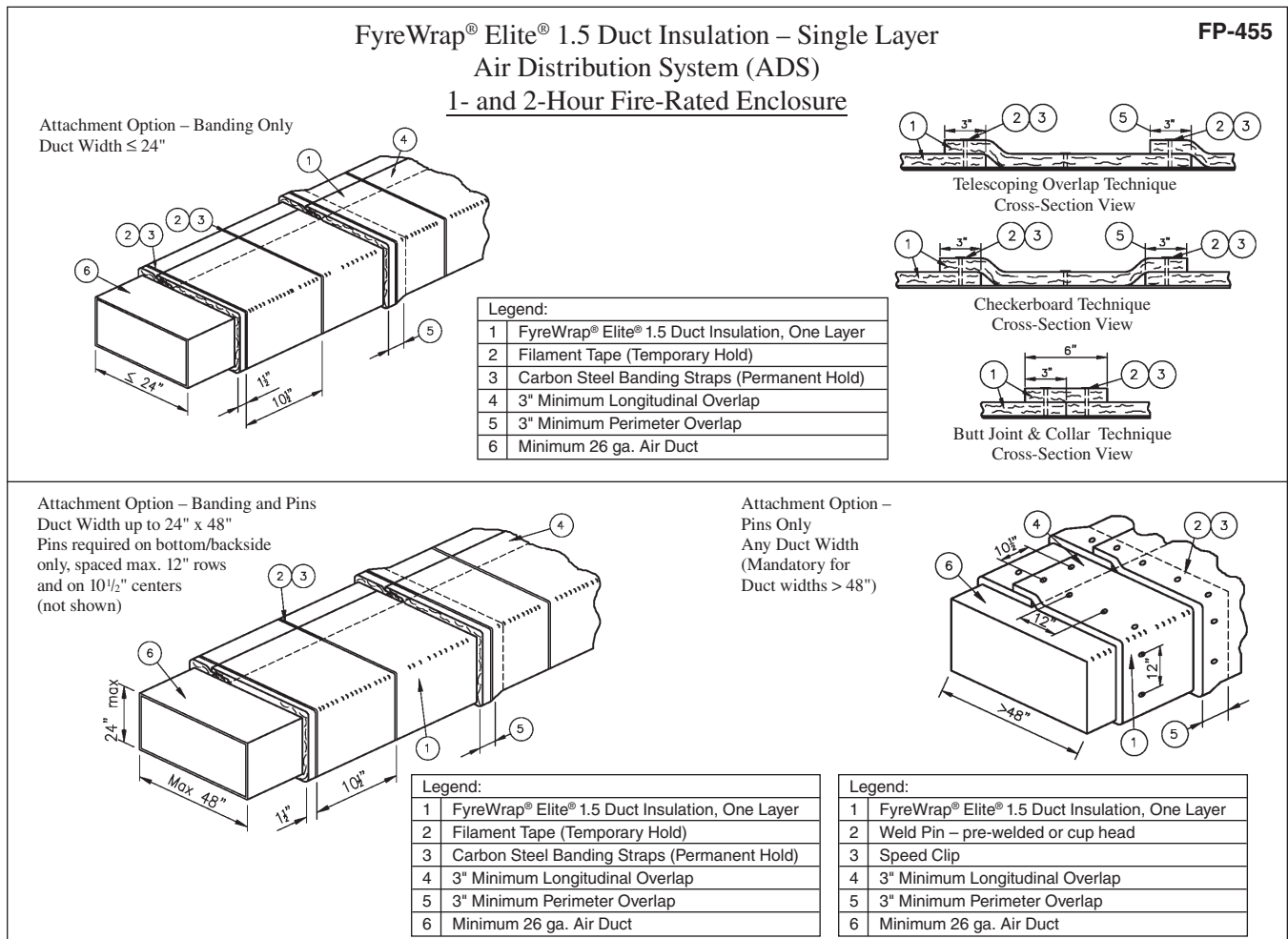

Figure 1. FyreWrap Elite 1.5 Duct Installation – ADS System Installation Techniques



Attachment Options

Three attachment options are available for installers. The choices are limited by the duct width dimension. Details on each are provided below and shown in Figure 1.

Banding Only: For Duct Widths 24" or Less

To temporarily secure the insulation, optional use of filament tape is permitted. Place carbon steel or stainless steel bands (min. 1/2" wide, nom. 0.015" thick) over material joints and within the field between. Locate bands 1 1/2" from the edge of each blanket overlap. Place an additional band(s) between overlaps, spaced 10 1/2" on center. Tighten banding to firmly hold the wrap system in place but not so tight as to cut or damage the blanket and secure with minimum 1" long steel crimp clips. Pins are NOT required when the duct size falls within the above dimensions and this banding technique is used.

Banding and Pins: For Duct Widths ≤ 48"

Weld 12-gauge steel insulation pins to the underside of horizontal runs and backside (side of duct having largest dimension) of vertical duct runs. Place pins at maximum 12" rows and on maximum 10 1/2" centers. To temporarily secure the insulation, optional use of filament tape is permitted. Impale FyreWrap Elite 1.5 over the pins and secure with 2 1/2" square or 1 1/2" round galvanized steel speed clips (washers). Turn down or cut off exposed ends of pins to eliminate safety hazards. Locate carbon steel or stainless steel bands

(min. 1/2" wide, nom. 0.015" thick) 1 1/2" from the edge of each overlap joint. Locate an additional band(s) between overlaps, spaced 10 1/2" on center. Tighten banding to firmly hold the wrap system in place but not so tight as to cut or damage the blanket and secure with minimum 1" long steel crimp clips. Cup head style pins are also permitted and shall be located at the same spacing as pre-welded pins.

Pins Only: For Duct Widths > 48"

Weld 12-gauge steel insulation pins on all sides of the duct. Place insulation pins at maximum 12" rows and on maximum 10 1/2" centers. Pins in each row are maximum 6" from each duct edge. Locate insulation overlaps so they are centered on the pins. Impale FyreWrap Elite 1.5 over the pins and hold in place with 2 1/2" square or 1 1/2" round galvanized steel speed clips (washers) to keep the blanket from sagging. Turn down or cut off exposed ends of pins to eliminate safety hazards. Cup head style pins are also permitted and shall be located at the same spacing as pre-welded pins. The pins only attachment method can be used for duct widths less than 48", but is optional.

Supports

The duct support system shall be designed as required by IMC or SMACNA requirements and that will support the load of the ventilation air duct and the additional weight of the FyreWrap Elite 1.5 Duct Insulation ADS System under a fire load.

Attachment Options (Summary Chart):

Duct Dimension	Banding Only	Banding & Pins (Pins on Bottom)	Pins Only (All Four Sides)
Width ≤ 24"	●	●	●
Width ≤ 48"		●	●
Width > 48"			●

Firestop Systems

Where ducts insulated with FyreWrap Elite 1.5 pass through fire-rated walls and floors, the penetration opening shall be firestopped to maintain the fire rating of the assembly. Firestop systems tested per ASTM E119 and ASTM E814 are provided below. Additional Tested and Listed firestop systems may be available for use. For details and assistance, contact Unifrax at 716-768-6500 and ask for Fire Protection Application Engineering, or search the test laboratory web site directly for the latest documentation.



FyreWrap® Elite® 1.5 Duct Insulation
Through Penetration Firestop Systems
Intertek Design Nos. UNI/FRD 120-21,
UNI/FRD 120-23, UNI/FRD 120-24
Per ISO 6944, ASTM E814, ASTM E119
F-Rating = 2 hours, T-Rating = 2 hours

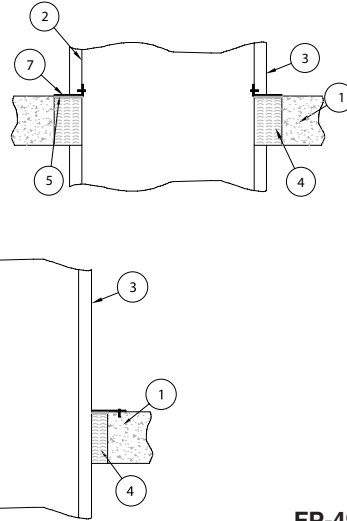
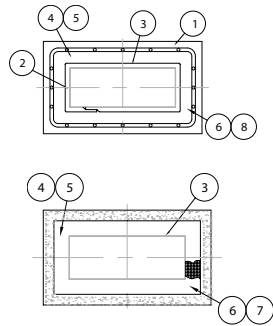

Legend:	
1	Concrete Floor Assembly, 4½" depth.
2	Air duct, min. 26 gauge, 1296 in² area, max. 54" width.
3	FyreWrap® Elite® 1.5 Duct Insulation, One Layer.
4	Unfaced FyreWrap® Elite® 1.5 Blanket, ¼" depth. Compressed 33%.
5	STI SpecSeal SSS, ¼". Plus ¾" Overlap On Concrete and duct insulation.
6	Annular Space, 1" to 2".
7	Duct Reinforcement: ½" thk. steel angle (1" tall vertical leg x horizontal leg dim. at least equal to width of annular space). Attach using ¼" dia. steel pop-rivets. Spaced max 6" O.C.
OR	
8	Min. ¼" thk. steel plate over the firestop sealant (compressing ductwrap ¼" and extending onto floor surface 2"). Attach with ¼" dia. concrete screws, spaced 6" O.C.

FP-495

Figure 2.

FyreWrap® Elite® 1.5 Duct Insulation
Through Penetration Wall Systems
Intertek (OPL) Design No. UNI/PHV 120-03, UNI/PHV 120-04
ASTM E814: F-Rating = 2 hours, T-Rating = 2 hours

FP-627

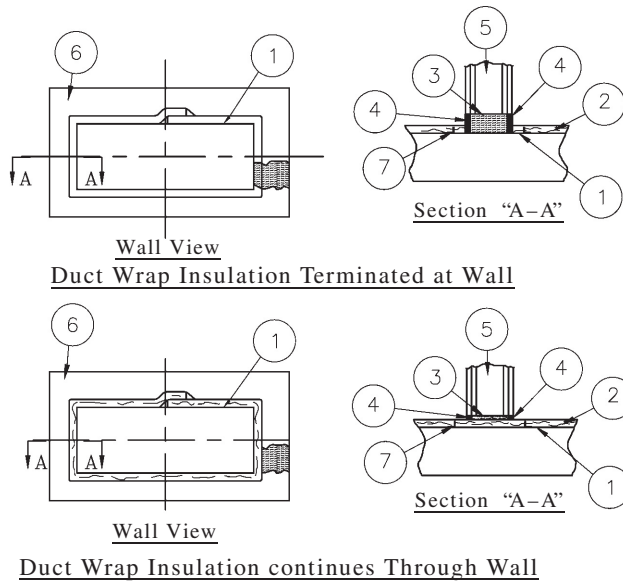

Legend:	
1	Air Duct, min. 26 gauge, 1296 in² area, 54" max. width
2	FyreWrap® Elite® 1.5 Duct Insulation, One Layer
3	Unfaced FyreWrap® Elite® (Compressed 33%>, recessed ½" on each side)
4	Firestop Sealant, ½" depth, overlapping on gypsum board and duct min. 1" 3M Fire Barrier 1000NS or Hilti FS-ONE or STI SpecSeal SSS or Tremco FyreSil
5	Gypsum Wallboard Assembly, 2 Hr. rated
6	Annular space, 1" to 1½"
7	Duct Reinforcement, 1" x 1" x ½" steel angle on all four sides of duct and located on both sides of wall

Figure 3.





FyreWrap products offer solutions in applications such as:

- Grease, Air Ducts
- Cable Trays, Conduits
- Control System Covers
- Above Ground Storage Tanks
- Marine Bulkheads, Decks
- Structural Steel
- Construction Joints
- Curtain Walls/Safing
- Circuit Protection
- Railroad Tank Cars
- Transit Cars
- Ships
- Expansion Joints
- Fire Door Seals
- Chimney Liners
- Ceiling Air Diffusers
- Hazardous Material Storage Containers

Unifrax has a wide range of FyreWrap fire protection materials available to provide passive fire protection solutions in a variety of applications in the commercial building, industrial facility and transportation industries.

For additional information about product performance or to identify the recommended product for your fire protection application, please contact Unifrax at 716-768-6500 and ask for Fire Protection Application Engineering.



CLASSIFIED
UL US

FACED BATTS & BLANKETS

SURFACE BURNING CHARACTERISTICS

FLAME SPREAD	25
SMOKE DEVELOPED	50

Issue No: _____

R14514



Intertek

Listed

W/N 14870

Reference
Intertek Directory
of Listed Products
www.intertek.com/directories/

APPLIED FIRE PROTECTION

UNIFRAX I LLC
New Carlisle, IN

FyreWrap® Elite® 1.5 Duct Insulation
Nominal Density: 6 pcf

Tested Per:
ASTM E119 - Fire Resistance Rating: 2 hour
ANSI/ASTM E814 - T-Rating: 2 hr F-Rating: 2 hour
ASTM E2336
CAN/ULC-S144
UL 1978 - Sec. 14 & 15 - Passed
UL 2221
AC 101 (Engulfment) - Passed
AC 101 (Internal) - Passed
ISO 6944 - Duct Type: A

Data are average results of tests conducted under standard procedures and are subject to variation. Results should not be used for specification purposes.

Refer to the product Material Safety Data Sheet (MSDS) for recommended work practices and other product safety information.



Form C-1496
Effective 8/13
© 2013, Unifrax I LLC
All Rights Reserved
Printed in USA
Page 6 of 6

The following are registered trademarks of Unifrax: FyreWrap, Elite, and Insulfrax.

The test data shown are average results of tests conducted under standard procedures and are subject to variation. Results should not be used for specification purposes.

Product Information Sheets are periodically updated by Unifrax. Before relying on any data or other information in this Product Information Sheet, you should confirm that it is still current and has not been superseded. A Product Information Sheet that has been superseded may contain incorrect, obsolete and/or irrelevant data and other information.

The logo for FyreWrap, featuring the word "FyreWrap" in a bold, italicized, sans-serif font. The "F" is significantly larger and partially overlaps the "yre". The text is white and set against a red background that tapers to the right.

Unifrax I LLC

Corporate Headquarters
600 Riverwalk Parkway
Suite 120

Tonawanda, NY 14150

Telephone: 716-768-6500

Canada: 1-800-635-4464

Internet: www.unifrax.com

Email: info@unifrax.com